



CDU-S Gas Cooler block replacement process

SandenVendo February 2023

This document presents the main steps for replacing the Gas Cooler block of a Sanden Condensing unit CDU-S

References:

Type	Model
CDU-S	R02A1A R02A1B R02A1D

100% CO2 Condensing units

ECO-FRIENDLY REVOLUTION

This document is the property of SandenVendo GmbH.
The illustrations in this document are given for information only.
SandenVendo GmbH reserves the right to modify information in
this document without notice.





Gas Cooler block replacement process

1. Turn power OFF the condensing unit.
2. Remove the CDU casing (left side + right side + front right and left + rear panel , and top panel)
3. Remove the Gas cooler protection grid (8 bolts)
4. Disconnect and Remove the Fan motor. (4 bolts)
5. Separate the Gas Cooler block from the CDU bracket by removing the fixing screws
6. Empty the refrigerant R744: by the suction valve, then by the supply valve.
7. Ensure that there is no remaining pressure on the loop.
8. Debraze and remove the failed Gas cooler block.
9. Prepare the new Gas Cooler block.
10. Brazing with nitrogen flux.
11. Leakage test at 80 bar , check brazing (see guide for piping work and start-up)
12. Reassembled and reconnect the Fan motor (4 bolts)
13. Turn power ON the condensation unit and check that there is no error code.
14. Vacuum of the loop for 3 hours
15. Reassembled all the fixing bracket.
16. Load R744 loop A : initial load determined at commissioning
17. Restart the entire installation, make sure it is working properly.
18. Close the panels

Gas Cooler block replacement process

2.Remove the CDU casing (left side + right side + front right and left + rear panel , and top panel)

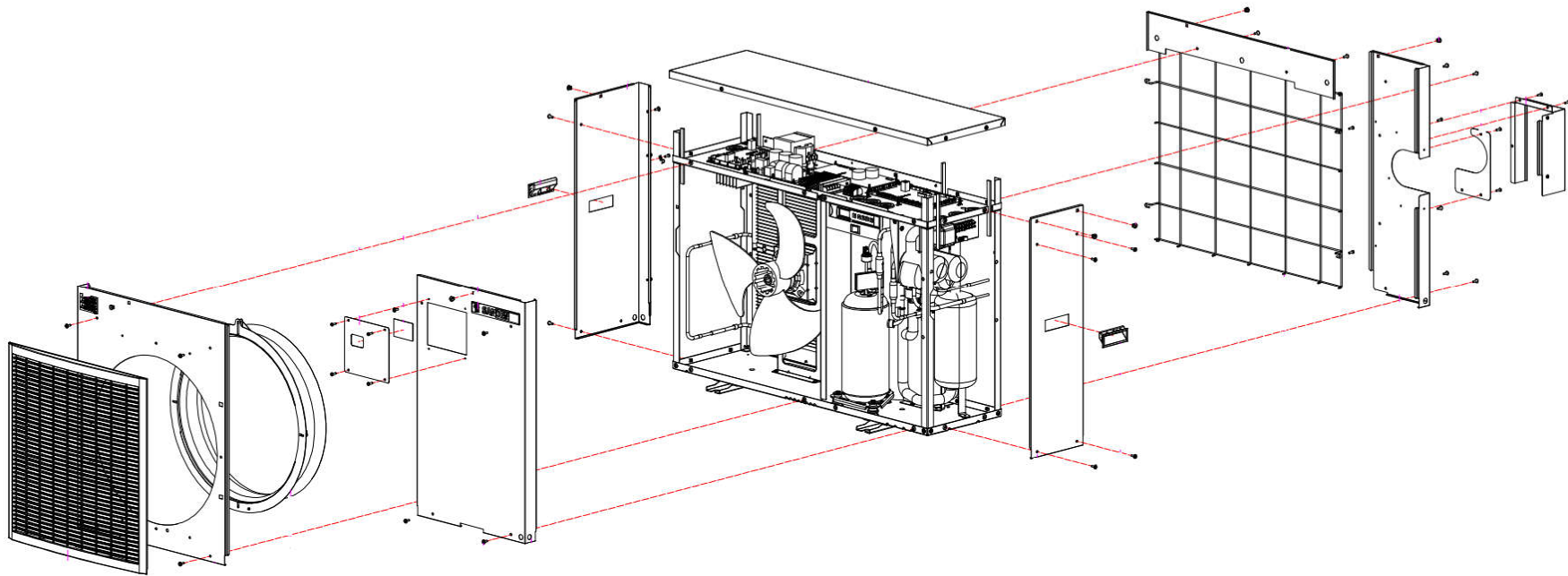

Gas Cooler block replacement process

4. Disconnect & Remove the Lower Fan Motor.

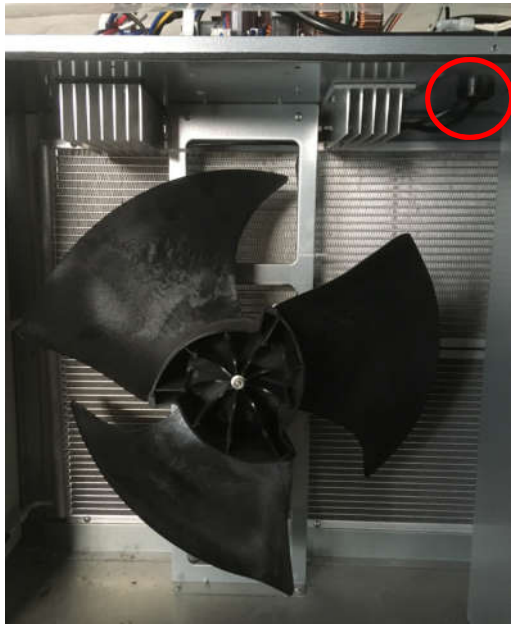

Disconnect fan motor harness



Unscrew the 4 bolts of the fan motor



Remove the Colson



Remove the fan motor assembly

Gas Cooler block replacement process

5. Separate the Gas Cooler block from the CDU bracket by removing the fixing screws

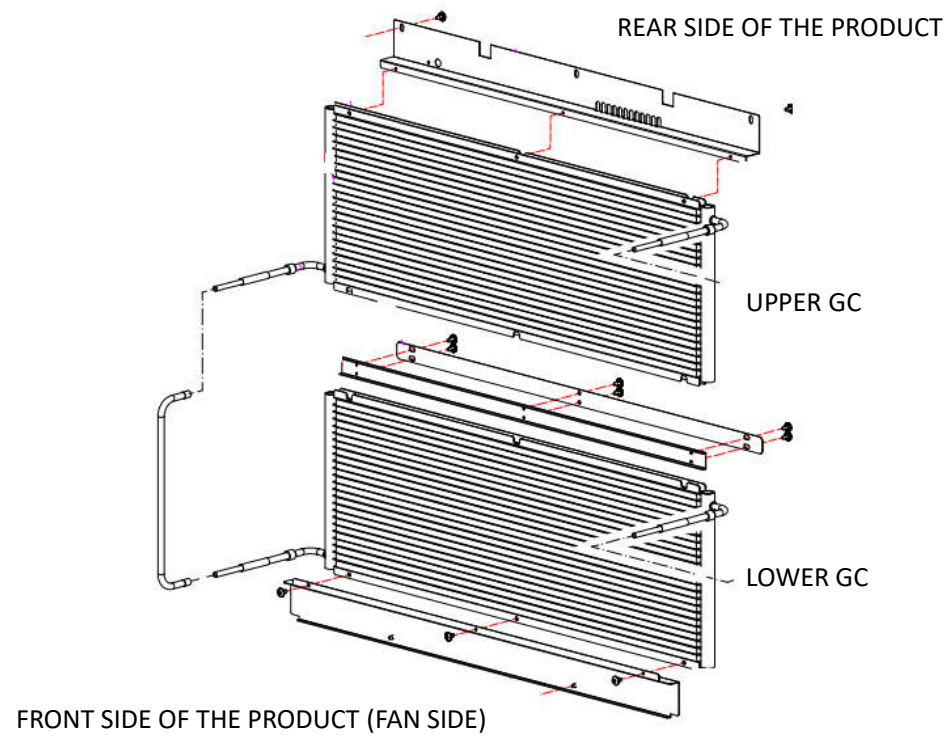

Gas Cooler block replacement process

6. Empty the refrigerant R744

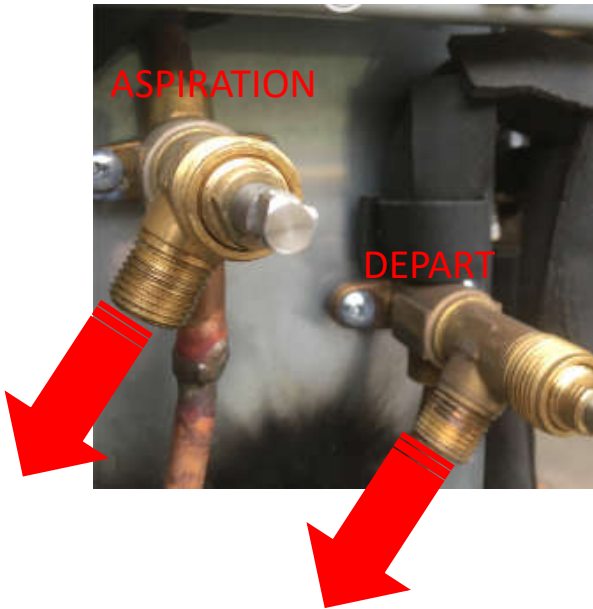

First by the suction valve and then if necessary by the supply valve.

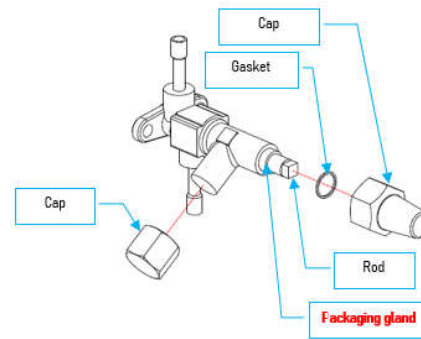

Loosen the packing gland before any manipulation of the rod.
Tighten the packing gland when the manipulation of the rod is finished.
Failure to loosen the packing gland may cause damage to the rod as well as valve leaks.

Gas Cooler block replacement process

8. Debraze the failed Gas cooler block.



FAN SIDE



COMPRESSOR SIDE

Gas Cooler block replacement process

8. Remove the failed Gas cooler block.



Bloc Gas Cooler assembled



Bloc Gas Cooler disassembled