

Evaporator configuration

CDU-S

CDU-M

CDU-L

1. Single evaporator
2. Multi evaporator
3. CDU control logic

Oct 2021

100% CO₂ condensing units

ECO-FRIENDLY REVOLUTION

This document is the property of SandenVendo GmbH.
The illustrations in this document are given for information only.
SandenVendo GmbH reserves the right to modify information in
this document without notice.





CDU-S

- Only for MT application
- One refrigeration loop (CLA) without subcooler
- Evaporator volume until 15 liters (1)

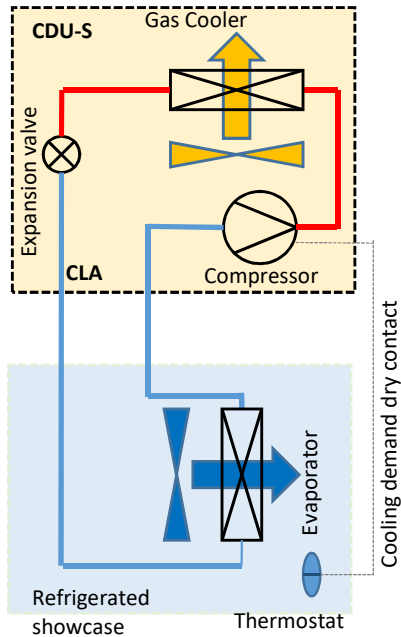

CDU-M :

- MT or LT applications
- One loop (CLA) with sub cooler (loop C)
- Evaporator volume limited to 15 liters in MT and 5 liters LT (1)

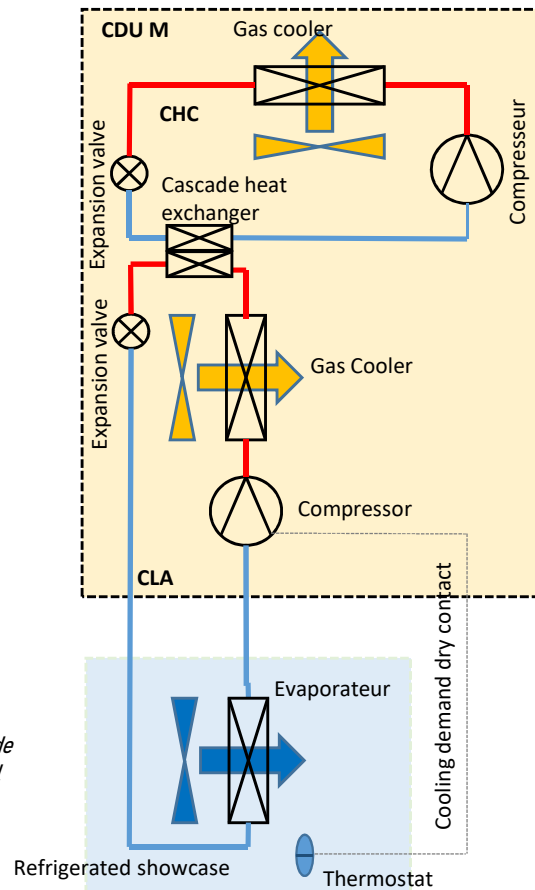

1.1 Single evaporator

CDU-L :

- MT and/or LT applications
- Two independant loop (CLA et CLB) with subcooler (loop C) (2)
- Evaporator volume limited to 15 liters in MT and 5 liters LT (1)

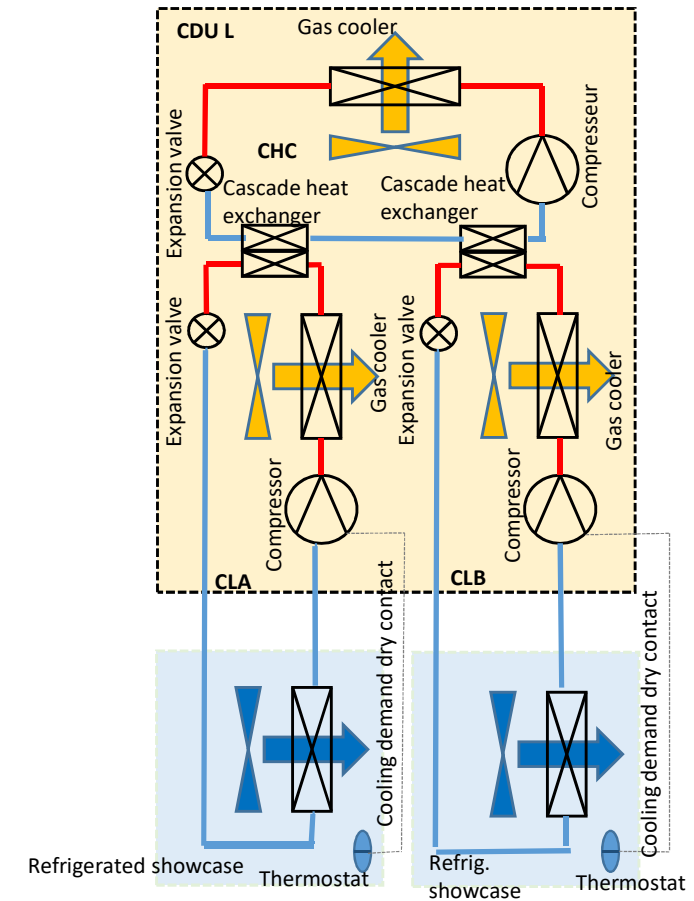

(1) See piping lenght recommendations and oil addition in dedicated model guide
 (2) CDU-L : On loop can run with single evaporator and the other one with mutl evaporator



1.1 Single evaporator installation

CDU-M

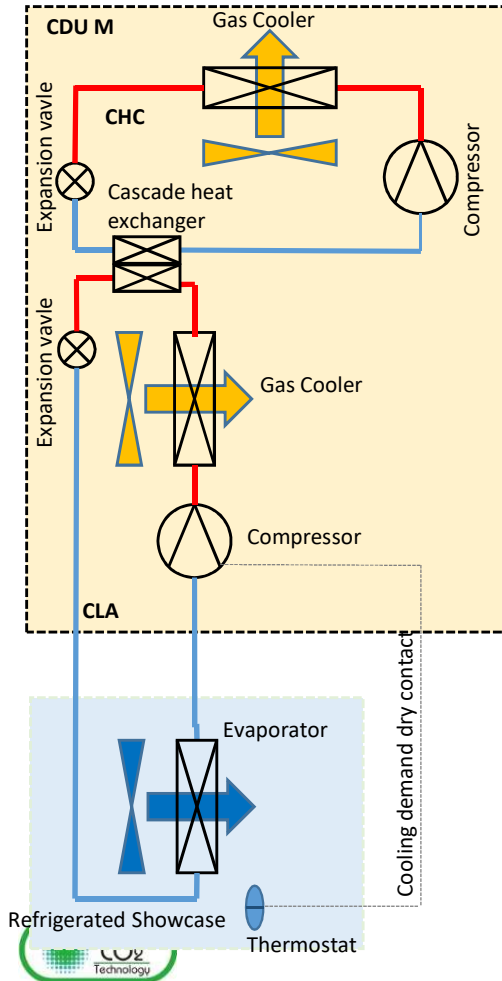

Single evaporator operation

- An electronic expansion valve is integrated to the condensing unit on each refrigeration loop. Therefore, it's not necessary to add an expansion valve to the evaporator.
- Install a controller or a thermostat to manage cooling demand delivered to the condensing unit. This controller will also manage the evaporator defrost cycles while stopping the cooling demand.
- The compressor speed controls suction low pressure.
- The integrated expansion valve expands the CO2 and control the High Pressure to the calculated optimum.
- The superheat is set with CO2 loading in the loop during the commissioning.

Recommendations:

Prefer an evaporator sized 80 bars. Otherwise, install at least a 60 bar evaporator. In this case, install a safety valve to protect the evaporator on the suction line. For cold rooms, do not put the door opening contact on the cooling demand. This can result in a temperature drift in the cold room during the day.



WARNING : The cooling demand to the unit must be potential free (dry contact)

Condensing Unit **CDU-S & CDU-M**

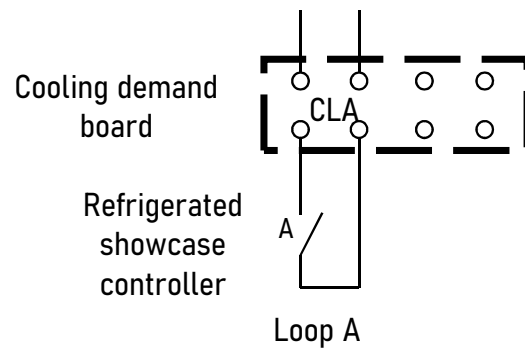

Condensing Unit **CDU-L**

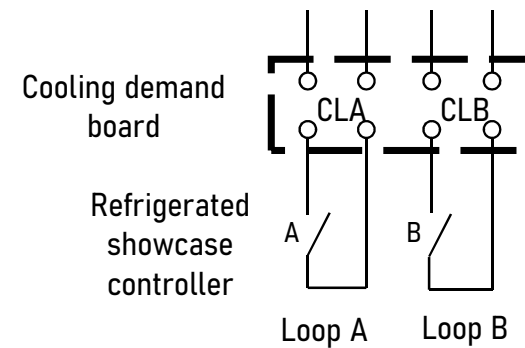

1.2 CDU-L specific single evaporator

Specific single evaporation operation

- To increase the cooling capacity on one evaporator, the two CDU-L loops are connected to the evaporator with two different circuits
- An electronic expansion valve is integrated to the condensing unit on each refrigeration loop. Therefore, it's not necessary to add an expansion valve to the evaporator.
- Install a controller or a thermostat to manage cooling demand delivered to the condensing unit. This controller will also manage the evaporator defrost cycles while cutting the cooling demand.
- **In this case, only one controller is necessary and one cooling demand is delivered to the group. The two inputs CLA and CLB are then connected in parallel to the electronic board.**
- The two loops operate at the same time, their operation is the same as in the normal single-evaporator mode described previously.

Recommendations:

Prefer an evaporator sized 80 bars. Otherwise, install at least a 60 bar evaporator. In this case, install a safety valve to protect the evaporator on the suction line. For cold rooms, do not put the door opening contact on the cooling demand. This can result in a temperature drift in the cold room during the day.



WARNING : The cooling demand to the unit must be potential free (dry contact)

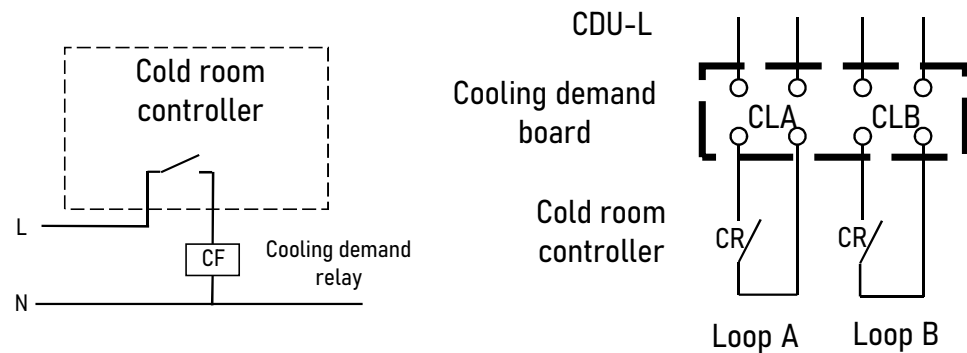
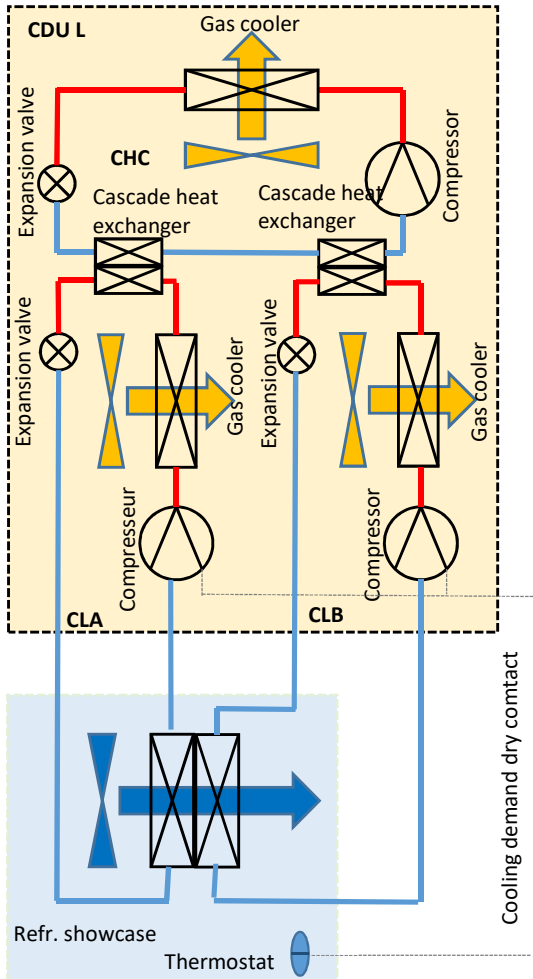

2.1 CDU Multi evaporator installation

CDU Multi evaporators:

- The multi-evaporators operation is possible on MT application for each loop of condensing unit range.
- The evaporator volume is limited to 15 liters in MT (*See piping length recommendations and oil addition in dedicated model guide*)
- Maximum number of evaporators on one loop : 4 maximum. Beyond 2 evaporators, consult SandenVendo

Multi evaporators operation :

- An expansion valve is installed at each evaporator inlet
- At least, a pressure sensor is installed on suction line
- The temperature sensor located at evaporator outlet (S2) have to be placed outside from the refrigerated showcase or the cold room to create an increased superheat.
- Associate cooling stations to similar application temperatures. If not possible; you can add a **constant pressure valve** (KVP type) on the unit which has the higher evaporating temperature.
- Distribute the cooling capacity in a balanced way on the evaporators of the same loop. If this is not possible, select similar expansion valve orifices for the evaporators of a loop (i.e. avoid a too small orifice on an evaporator of low capacity compared to the other evaporators of the loop)
- Gather the evaporators of a loop in a restricted area to avoid too long piping network
- Balance the distribution network on the loop.

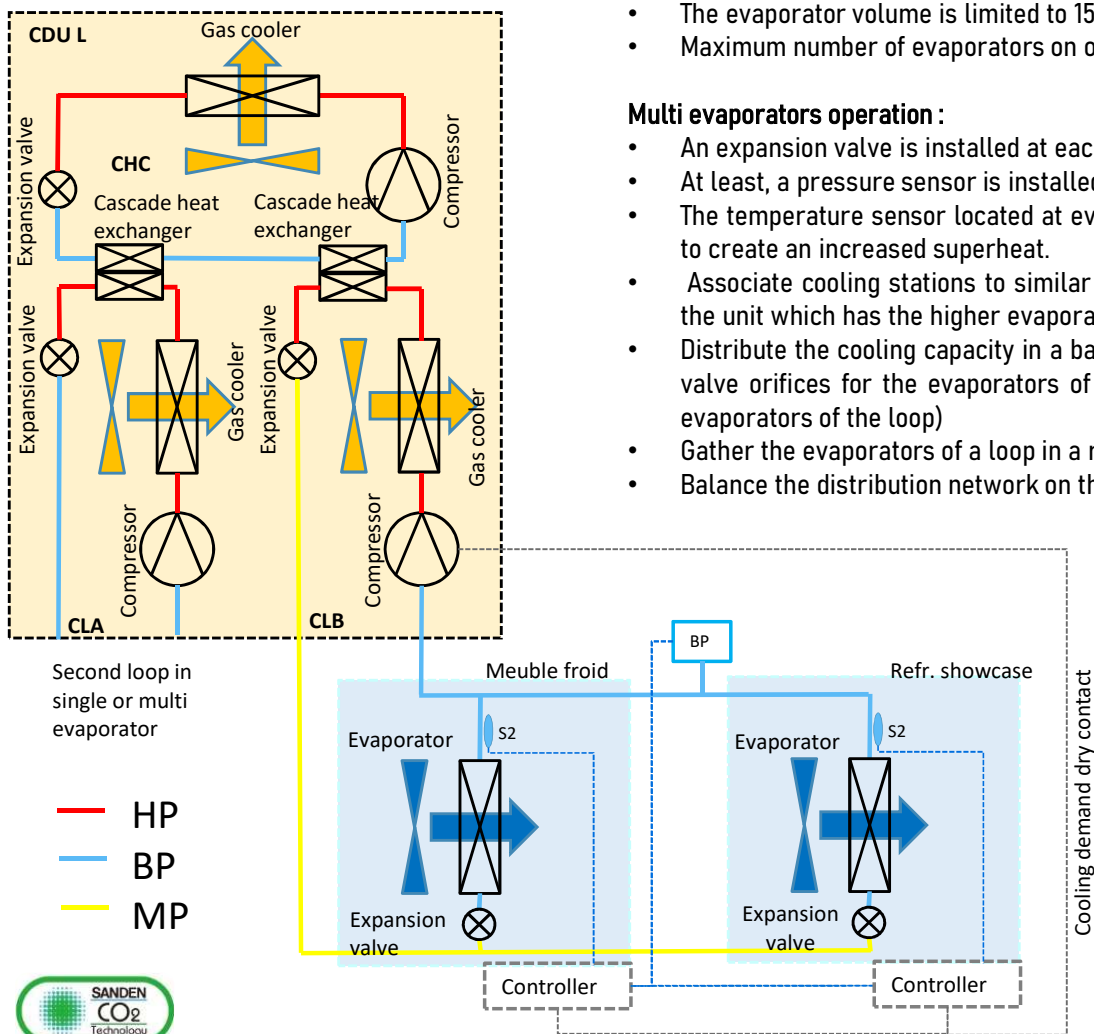

- Multi-evaporators operation requires coordination of controllers on defrost cycles
- It's necessary to keep the expansion valve opened on the loop when there is a regulation stop or a defrost to avoid high pressure cuts at the condensing unit level during its stop phase

WARNING : The cooling demand to the unit must be potential free (dry contact)

Recommendations:

Prefer an evaporator sized 80 bars. Otherwise, install at least a 60 bar evaporator. In this case, install a safety valve to protect the evaporator on the suction line.



These information are just examples,
Wiring and controller settings are under the responsibility of the installer

2.2 Multi evaporator installation with Danfoss controller

Wiring 3 cooling stations

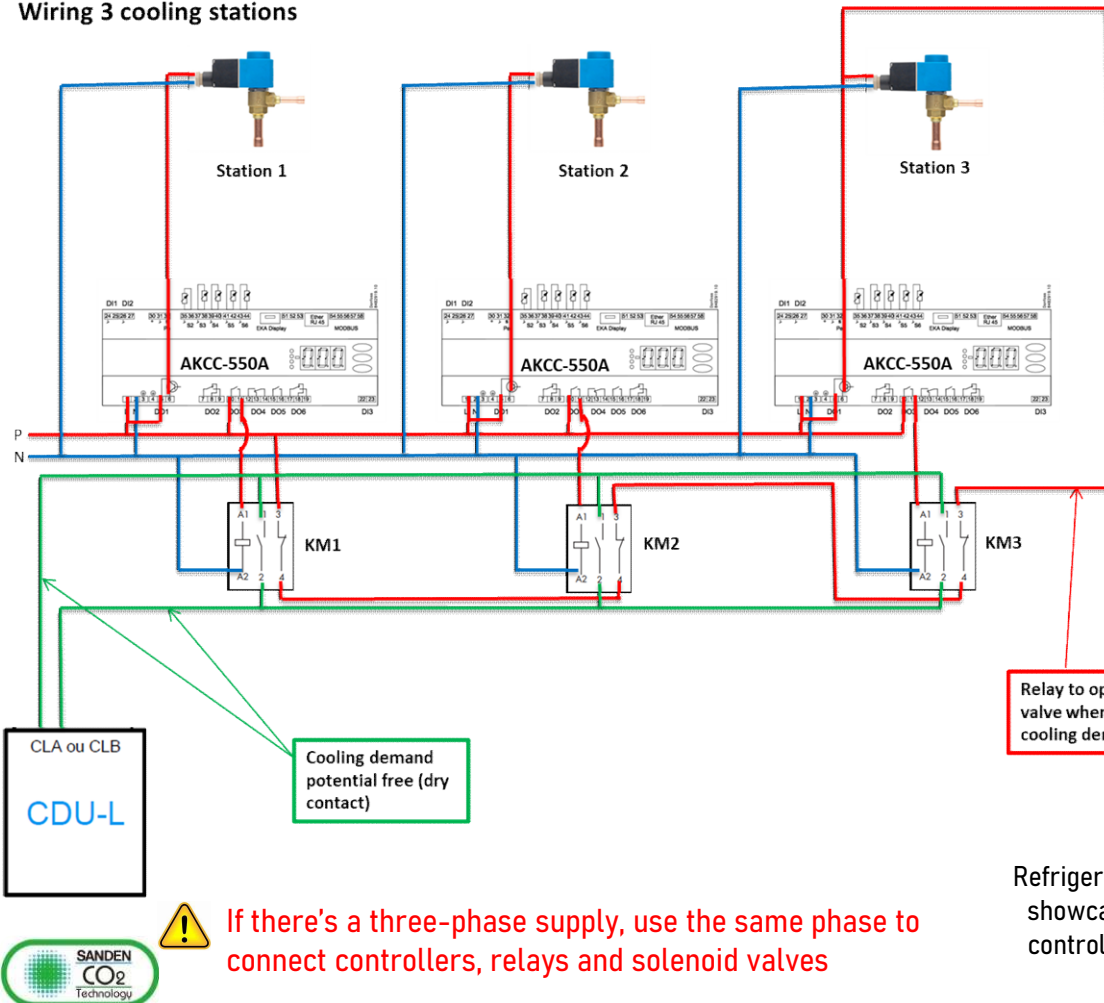

AKCC 550 / AKCC 550A controllers
Expansion valve AKVH managing On/Off function 230V

Parallel relay of the cooling demand from each regulator (cooling demand on dry contact to the unit)

Supply (opening) of a direct expansion valve when all the stations have reach setting point or during a defrost stop. This is to avoid a HP cut of the group during its shutdown phase.

Coordination of the necessary defrosts of the evaporators to obtain a shutdown of the condensing unit. Definition of a master or supervision controller or even identical defrost program in the different devices

AKCC 550 / 550 A Settings

- R01 : differential=1K
- R14 : controller= 1 (start/ stop)
- R16 : Melt interval function = 10
- N09 : Maximum superheat= 8K
- N10 : Minimum superheatg = 2K minimum possible
- N11 : no MOP = 15
- o20 : minimum range pressure sensor= -1
- o21 : maximum range pressure sensor = 59
- o30 : R744

Condensing Unit

Warning : the cooling demand to the group must be potential free (dry contact)

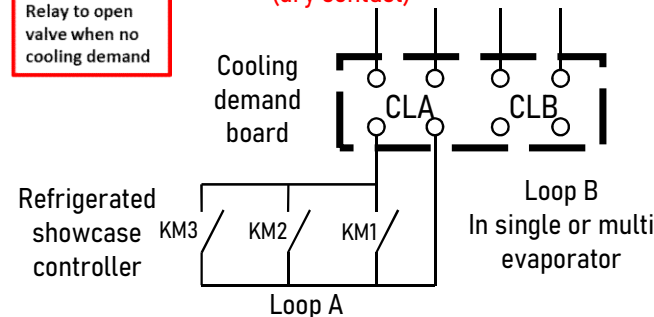

Controller System (logic control)

1. A cooling demand is sent to the CDU (CLA/ CLB loop) through the dry contact input
2. The compressor is in starting phase and accelerate gradually.
3. The real compressor speed (Ci) reach a setpoint calculated by the controller (CO)
4. The compressor speed manages the Low Pressure (Ps) in accordance with the Low Pressure setpoint (Ps0) initially set by the installer (parameters A02/B02). This low pressure is set depending on evaporating temperature recommended by the showcase or evaporator manufacturer
5. After the start-up phase, the CDU controller select a High Pressure setpoint (Pd0) according to the outside ambient temperature and the Low Pressure setting.
6. The electronic expansion valve will control its opening (Tr) in order to have the real High Pressure (Pd) reaching the High Pressure calculated setpoint (Pd0).
7. The total superheat ,determined with suction temperature (Ts) and evaporating pressure (Ps), is an information about the CO2 load of the system. This superheat must be between 5K and 10K.
8. Depending on the CDU model, the subcooler (Loop C) can start to maintain the cooling capacity.
The authorization of the C loop is conditioned by the type of application (positive or negative) as well as by the outside temperature.
The start and stop of the Loop C depends on the temperature difference between the inlet and the outlet of heat plate exchangers.
9. When the showcase or the cold room has reached its setpoint, the cooling demand to the CDU is stopped. The compressor is starting a gradual shutdown phase and the expansion valve moves to an open position. The fans stop.
10. An anti-short cycle timer of 5 minutes prevents the group from restarting in the meantime.

In case of multi evaporators installation :

7 bis Devices and expansion valves of each cooling station can control the local superheat depending on parameter set by the installer. As a result, an intermediate pressure takes place between expansion valve of the CDU and the expansion valves of the evaporators when theses ones are starting to close.

9 bis When all of the evaporators have reached their set point, the cooling demand to the CDU is stopped, and the CDU begins its stop phase. To avoid a HP cut during this shutdown phase, one of the expansion valve of the cooling loop is forced to opened by remaining powered.

Defrost logic

1. The defrost operation is managed by the showcase or the cold room controller. When the evaporator is starting a defrost phase, the cooling demand to the condensing unit must be stopped
2. The condensing unit then enters in a shutdown phase: the compressor gradually stops, the expansion valve opens and the fans stop.

In multi evaporator configuration:

1. The coordination of defrosting of all evaporator of the loop is necessary to ensure condensing unit stop during defrosting.
2. As for a shutdown of showcase controlling, one of the evaporator expansion valves must remain powered in order to avoid any HP cutout during this shutdown phase for defrosting.