



# CDU Sanden

## Software guide OLD GENERATION

- 1/ Operating display
- 2.1 to 2.3/ Software release checking
- 3.1 & 3.2/ Setting menu
- 4.1 to 4.3/ Setting CDU

# 1/ Operating display

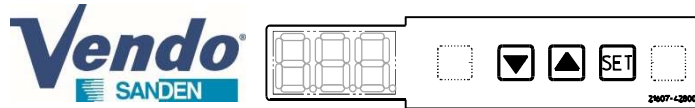

## 1/ Display

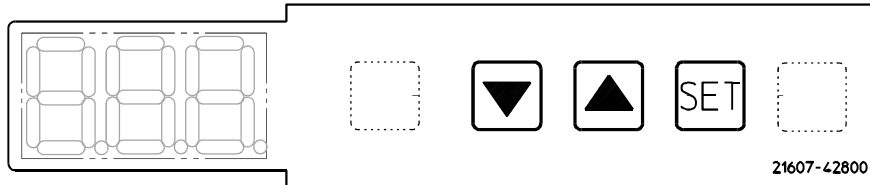

Name	Function
SET button	Scroll through configured values
▲ button	Edit settings (increase)
▼ button	Edit settings (reduce)
	Displays the normal low-pressure value. Displays the setting value in setting value adjustment mode, and displays each data point in RAM display mode.
	Flashes when sending or receiving communication data between the master unit and the slave unit (period after the first right-hand digit).

## 2/ Initializing display

When the condensing unit is turned ON, the display starts showing the following information up to the normal low pressure value :

[*000*] ← Display LED test

[*0.2*] ← C02 general indication

[*\*.\**] ← Software version : ← Old version [*0.0*] to [*0.2*]

[*! n!*] ← Indication that the condensing unit made the initialization

[*\*\*.\**] ← Low pressure current value CLA (normal condition)

## OLD GENERATION SOFTWARE

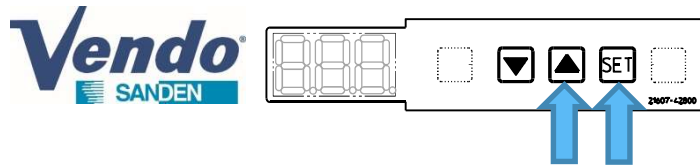

## 2.1/ Software release checking

Checking release is the same process as new generation software

Press and hold ▲ & SET buttons for 3 seconds when normal mode is displayed.

- The display shows "r00"
- Press shortly ▼ to display "r5U"
- Press "SET" from "r5U" to display the Software version.
- The display shows the Software version ( Example : U0.3...)
- Press and hold "SET" button for 3 seconds to finish, after that the indication change to normal mode.

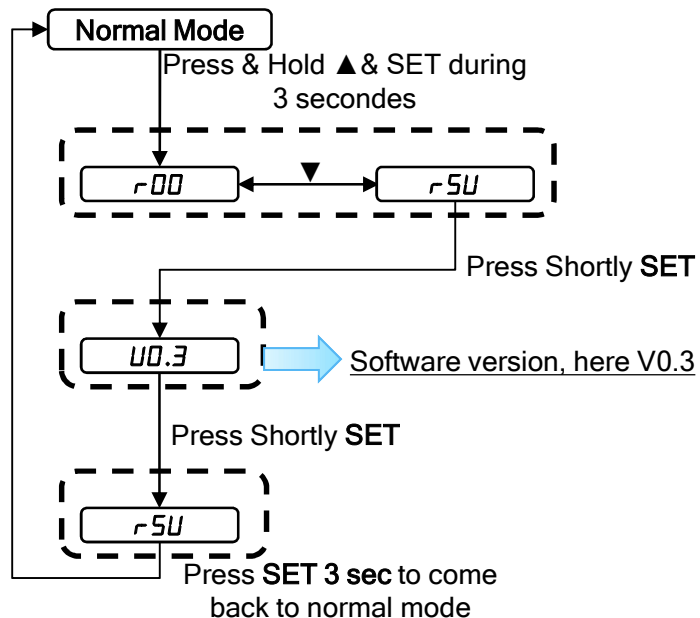

Other possibility to check the software release :

- From the initialization phase of the condensing unit, just after switch ON the power supply.
- Check 1st slide : 1/ operating display*

## OLD GENERATION SOFTWARE

# 2.2/ Software release checking

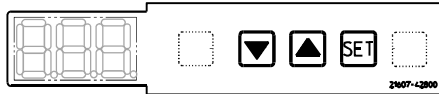

Software SCU		Release *	date release **	ref PCB controller (for information)	Description
OLD GENERATION	8B2 to 8B5	U0.0 to U0.2	2016 to 2018	one reference per model	<b>OLD GENERATION CDU SOFTWARE (refer to old software guide for operating instruction)</b> -One soft per model of CDU -Low Temperature mode not managed (=> Move Cooling to freezing appliance by changing over 10 parameters)
		NEW GENERATION	8B6	U4.3	March 19
8B7	U0.3		June 20	4590170H10	-Can replace the previous one -Automatic recognition Panasonic compressor -Discharge temperature control optimization -Improvement Fan motor error detection
8B8	U0.5 (V0.51)		May 22	4590336H10	-Can replace the previous one -Low pressure cut alarm display (E41) -High pressure alarm (E01) & Discharge Temperature (E02) available on alarm output 230V (configurable) -Correction Low pressure target writing from Modbus (Configurable) -Error history menu
	U1.0 (V1.01)		July 22	4590336H11	-Can replace the previous one -Loop C EEV minimum opening set at 200pls (C52) -Software release visible through the reading parameters

OLD GENERATION SOFTWARE

All about new software generation, → refer to the up to date software guide

\*Check the software release during initialisation of the product after power supply ,  
 Or by checking with the display, follow the instruction described in the previous slide ,  
 Or by the reading parameters (accessible by this way only from the last software release 8B8 V1.01)  
 \*\* the date of the software release may differ from the date of production of the condensing unit

## OLD GENERATION SOFTWARE

## 2.2/ Software release checking

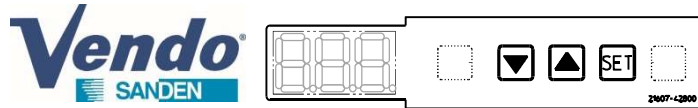

Indication about the software release embedded in the unit

CDU type	Model	Voltage	Country	Software generation
CDU-S	R02A1A	230V 3ph+N	Japan	OLD Generation
	R02A1B	230V 1ph+N	Japan	Check release (manufactured with OLD one , but may be updated by NEW before delivery)
	R02A1D	230V 1ph+N	Italy	NEW Generation
CDU-M	R04A1A	230V 3ph+N	Japan	OLD Generation
	R04A1B	230V 1ph+N	Japan	Check release (manufactured with OLD one , but may be updated by NEW before delivery)
	R04A1B-Z1	230V 1ph+N	Japan	NEW Generation (V4,3)
	R04A1C	400V 3ph+N	Italy	NEW Generation
	R04A1D	230V 1ph+N	Italy	NEW Generation
CDU-L	R06A2A	230V 3ph+N	Japan	OLD Generation
	R06A2B	400V 3ph+N	Japan	Check release (manufactured with OLD one , but may be updated by NEW before delivery)
	R06A2C	400V 3ph+N	Italy	NEW Generation

# OLD GENERATION SOFTWARE

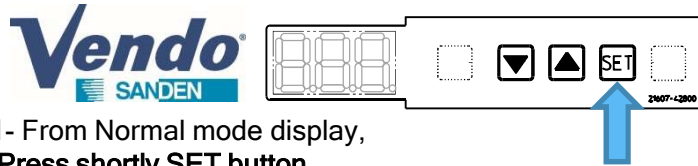

- 1- From Normal mode display, Press shortly SET button.
- 2- Choose with ▲ or ▼ button the Refrigerant Circuit [CLA, CLB or CHC]
- 3- Press shortly SET button to read the parameters of the following table. Scroll through Refrigerant Circuit with ▲ or ▼ button.
- 4- Exit : Press and hold SET for 3 seconds to exit reading and come back to Normal mode (or press any key for 1 minute)

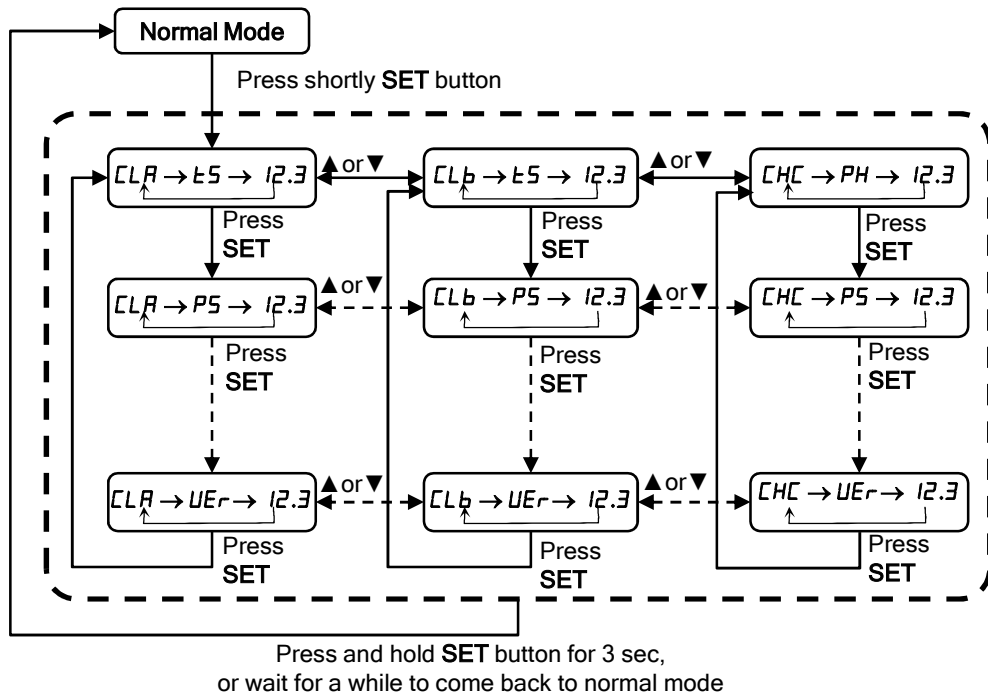

# 2/ Reading parameters

Checking Reading Parameters is the same process new generation software

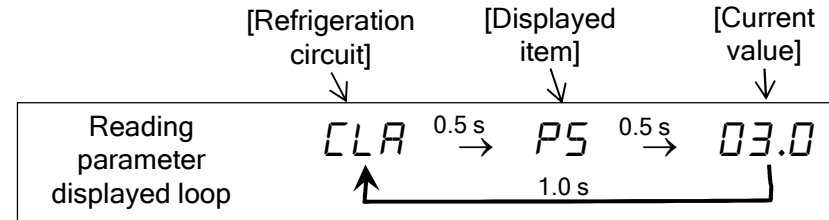

N°	Cooling loop	Code	Content	Unit
1	A / B	ES	Suction Temperature sensor input	°C
	C	PH	Subcooler temperature calculation, difference between inlet and outlet (t <sub>i</sub> - t <sub>u</sub> )	K
2	A / B / C	PS	Suction pressure (LP)	MPaG
3	A / B / C	Pd	Discharge pressure (HP)	MPaG
4	A / B / C	Ed	Discharge temperature sensor input	°C
5	A / B / C	tI	Subcooler inlet temperature sensor input	°C
6	A / B / C	tU	Subcooler outlet temperature sensor input	°C
7	A / B / C	Er	Electronic expansion valve position	Pulse
8	A / B / C	LI	Inverter compressor motor operating frequency	Hz
9	A / B / C	toL	Electronic enclosure temperature sensor input	°C
10	A / B / C	EAR	Ambient air temperature sensor input	°C
11	A / B / C	FF1	Gas cooler fan rotation speed (lower side)	rpm
12	A / B / C	FF2	Gas cooler fan rotation speed (upper side)	rpm
13	A / B / C	Fu1	Gas cooler fan control voltage (lower side)	V
14	A / B / C	Fu2	Gas cooler fan control voltage (upper side)	V
15	A / B / C	P5o	Target suction pressure	MPaG
16	A / B / C	Pdo	Target discharge pressure	MPaG
17	A / B / C	Lo	Inverter compressor motor target frequency	Hz
18	A / B / C	SLU	Software release (since SCU 8B8 MRT5 V1,0)	-
19	A / B / C	UEr	Software release (since SCU 8B8 MRT5 V1,0)	-

Remark : There is no reading parameters loop B for CDU-M  
There is no reading parameters loop B an loop C for CDU-S

## OLD GENERATION SOFTWARE

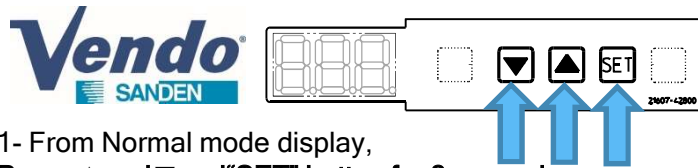

1- From Normal mode display, Press ▲ and ▼ and “SET” button for 3 seconds, to enter in parameter setting menu.

### 1<sup>st</sup> step (example of modification with A02):

Choose a list of parameter to modify :

CLA : list of parameters Loop A, Axx parameters

CLb : list of parameters Loop B, Bxx parameters

CHC : list of parameters Loop C, Cxx parameters

2- The display shows “CLA” first,

3- Press shortly ▲ or ▼ button to select the submenu to modify

4- Press shortly “SET” button to enter in the desired submenu

### 2<sup>nd</sup> step (example of modification with A02):

5- The display shows the 1<sup>st</sup> parameter of the list “A01” and “02.0”, alternately every 0,5 seconds (the parameter and its value).

6- One or more short press on “SET” to go down on the parameter to be modified.

7- Press shortly ▲ or ▼ button to set the desired value.

8- If there are other parameters to modify in this list : one or more short press on “SET” to go down to the parameter to be modified. If not, go to the next point.

9- Exit : Press and hold SET for 3 seconds to exit and come back to Normal mode (or press any key for 1 minute)



**Important: browsing in the settings menu gives access to a large number of settings. Please modify only the parameters indicated in this guide and as required.**

## 3.1/ Settings menu : setting process parameter A/B/C



OLD GENERATION SOFTWARE : there is one release per model CDU S , M or L. Avoid using a PCB controller with Old software generation for service

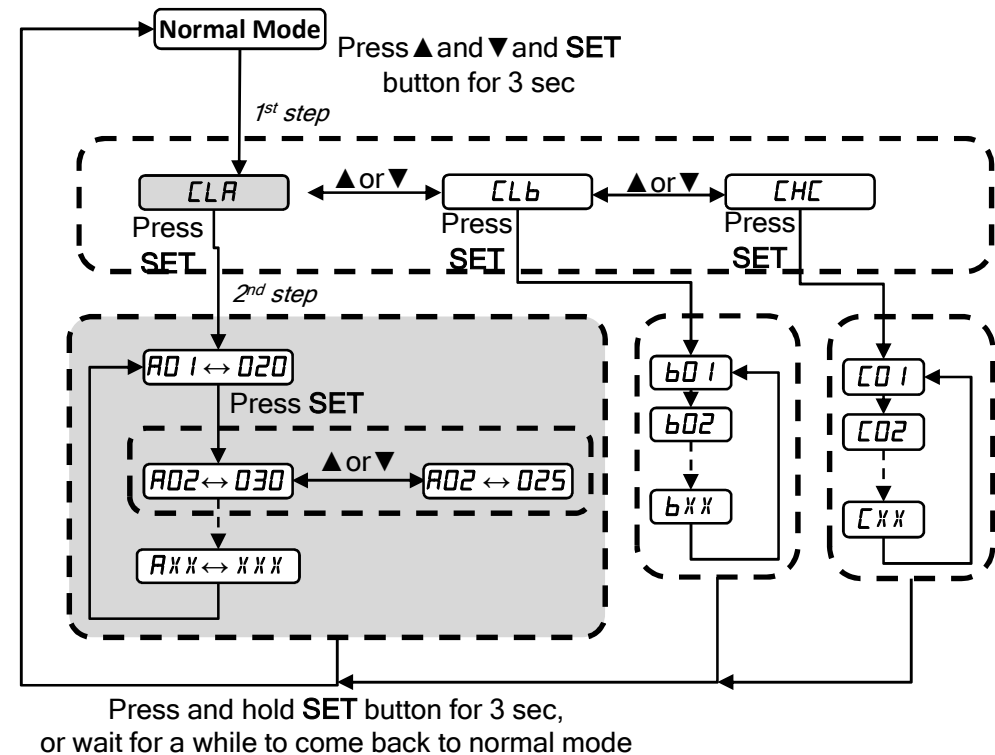

**Remark :** There is no setting parameters loop B for CDU-M  
There is no reading parameters loop B an loop C for CDU-S

## OLD GENERATION SOFTWARE

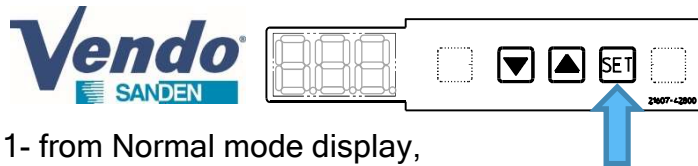

- 1- from Normal mode display, Press "SET" button for 3 seconds.
- 2- The display shows "P00" and "xxx" alternately every 0.5 seconds (depending on the of CDU)
  - 000 is CDU-L
  - 001 is CDU-S
  - 002 is CDU-M
- 3- Press "SET" button successively until the desired parameter
- 3- Press shortly ▲ or ▼ button to set the desired value.
- 4- Press "SET" button to the next parameter
- 5- Exit : Press and hold SET for 3 seconds to exit and come back to Normal mode (or press any key for 1 minute)

- ! -Parameters P are common for all the loops
- ! -Changing the parameter P00 creates error code because of the wrong selection of the model of CDU

## 3.2/ Settings menu : setting process parameter P



OLD GENERATION SOFTWARE : there is one release per model CDU S , M or L. Avoid using a PCB controller with Old software generation for service

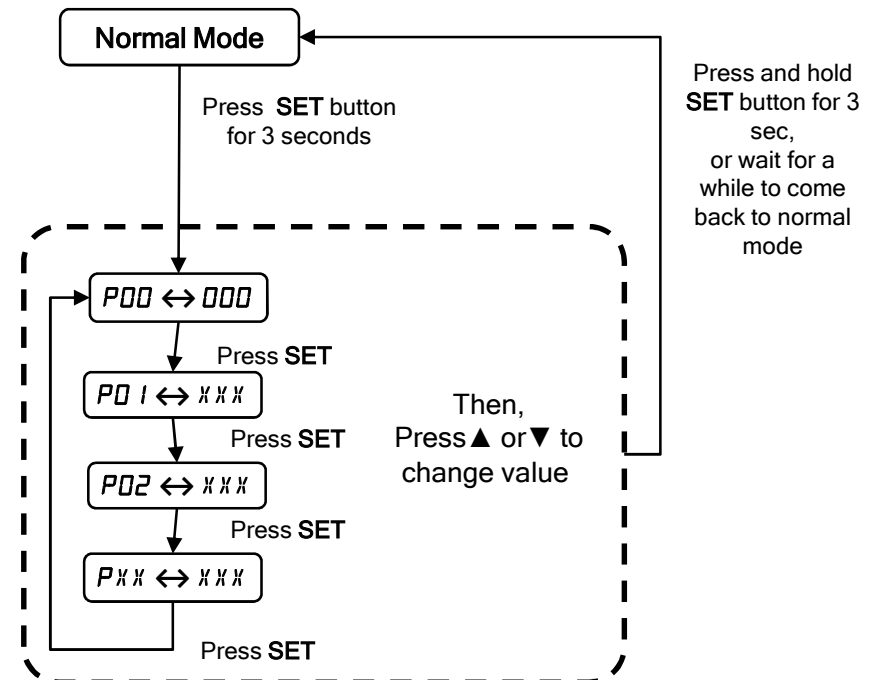



OLD GENERATION SOFTWARE

CDU-S R02A1A / R02A1B

## 4.1/ CDU-S Parameters adjustment according to evaporator temperature set point

R02A1B : check well the software release and confirm the old software before modifying the parameters below

Parameter	Unit	Fctory set	Tev ≥ -5°C	Tev ≥ -10°C
P08 MIN Low Pressure for Comp- ON	MPa	3.0	3.0	3.0
A01 MIN Low Pressure (Low Pressure Cut)	MPa	2.0	2.0	2.0
A02 Target Low Pressure	MPa	3.0	3.0	2.5
A04 MIN T° Ambient Comp OFF	°C	-20	-30	-30
A05 MIN T° Ambient Comp ON	°C	-15	-25	-25
A14 MAX T° amb for HP Calculation	°C	32	32	26



