



# Check operation & replacement process Electronic Expansion valve (EEV)

SandenVendo February 2022

This document explains how to check function of the EEV and the process to replace it on condensing unit

SANDEN VENDO CDU-S / CDU-M and CDU-L

## References:

Type	Model
CDU-L	R06A2A R06A2B R06A2C
CDU-M	R04A1A R04A1B R04A1C R04A1D
CDU-S	R02A1A R02A1B R02A1D

Condensing units 100% CO<sub>2</sub>

# ECO-FRIENDLY REVOLUTION

This document is the property of SandenVendo GmbH.  
The illustrations in this document are given for information only.  
SandenVendo GmbH reserves the right to modify information in  
this document without notice.





1. EEV Initialization Phase at Power On
2. CDU behavior with EEV locked in opened position or with closing difficulty
3. CDU behavior with EEV locked in closed position or with opening difficulty
4. EEV coil checking
5. Replacement Procedure

# 1. EEV Initialization Phase at Power On

At each power-up the condensing unit performs an initialization phase of a few tens of seconds.

During this phase, the position of the EEV is reset according to the process below:

- When condensing unit is turned on, the EEV is forced to close for 20 seconds.
  - At first the EEV moves and closes. When you take in hand the EEV, it is possible to feel the vibration generated by the movement
  - Again during this closing phase and after 10 seconds, the EEV reaches its closed position. You can then hear the characteristic noise of the EEV coming in stop for 10 seconds ("tic tic").
- After 20 seconds, the closed EEV opens to reach its standby position (400pls). During this last phase it is also possible to feel the vibration generated by the movement. The EEV initialization phase lasts a total of 30 seconds

EEV Position (pulse)	CDU-S	CDU-M	CDU-L
Position mini	80pls (16%)	40pls (8%)	
Position maxi	480pls (100%)		
Position standby	400pls (83%)		
Position mini (Loop C)		200pls*	
Position maxi (Loop C)		480pls (100%)	
Position au repos (Loop C)		400pls (83%)	

\*Position mini since program release SCU 8B8 MRT5 V1.01 (july 2023)

Power up End of initialization

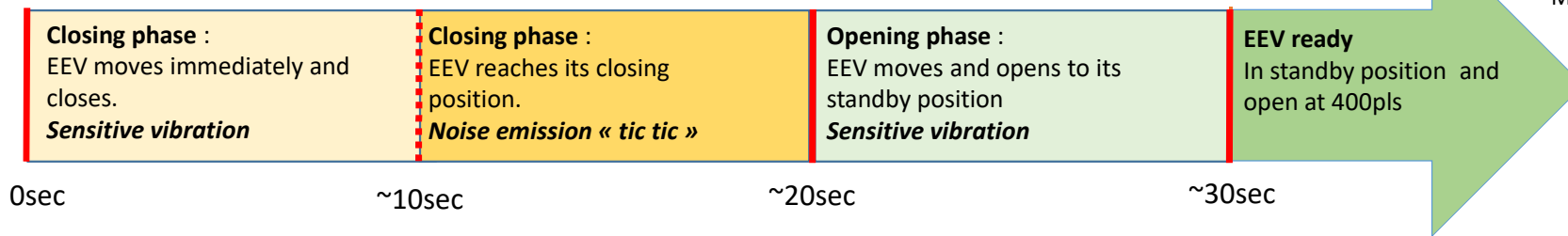

**The position of the EEV is given by the reading parameter Tr (stepper EEV from 40 to 480pls).**

**The parameter indicates the control of the EEV and not its actual position of the EEV.**

*Access to reading parameters : see CDU software guide & display*

There is no possibility of manual control of the EEV during its operation

There is no error code specific to an EEV failure

## 2 CDU behavior with EEV locked in opened position or with closing difficulty

Each EEV of the condensing unit controls the High Pressure of the loop on which it is installed (Loop A, B or C). The reading parameter Tr indicates the position of the EEV, it regulates so that the pressure HP (Pd) is at the target pressure (Pd0) calculated by the PCB controller.

*More precision on the condensing unit control, see CDU evaporator configuration.*

### Symptoms that may indicate an open blocked regulator malfunction and/or with closing difficulty (reduced operating range)

- There is a lack of cooling capacity observed
- HP pressure (Pd) does not reach the target value (Pd0). Therefore, the EEV control (Tr) indicates a low opening value and close to the minimum.  
By hand testing before and after the EEV, there must be a small temperature difference between upstream and downstream, if the EEV malfunctions
- In addition, the LP pressure (Ps) has difficulty lowering to its target value (Ps0). Thus the compressor (Ci) remains at a maximum speed of 80Hz
- **CAUTION: these symptoms may be associated likely with the compressor, which may have a poor compression ratio**  
If the observed compression ratio is really low, the failure comes rather from the compressor
- If the EEV malfunction is suspected, it is possible to swap the EEV coil with another coming from another loop in the unit
- The malfunction of the EEV can also be confirmed by taking it in the hand during the initialization phase described above. Shorter race times or a very low vibration sensation can confirm its bad condition

**CAUTION:** regarding loop C, the EEV minimum setting 200 pls does not always allow the high pressure (CHC Pd) to reach its target value (CHC Pd0), this operation is normal with rather low outside temperatures (<20°C) 20°C)

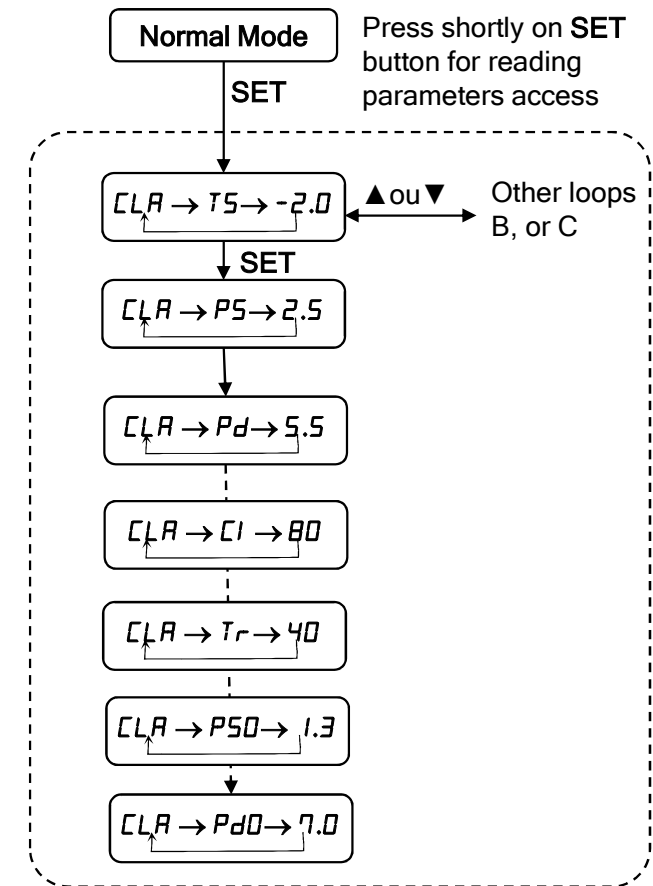

## 3 CDU behavior with EEV locked in closed position or with opening difficulty

Each EEV of the condensing unit controls the High Pressure of the loop on which it is installed (Loop A, B or C). The reading parameter Tr indicates the position of the EEV, it regulates so that the pressure HP (Pd) is at the target pressure (Pd0) calculated by the PCB controller.

*More precision on the condensing unit control, see CDU evaporator configuration.*

**CAUTION:** if the CDU loop is installed with multiple evaporation stations, the HP cut-off symptoms (E02) and the EEV control (Tr) with a very large opening (>400pls) are often associated with a malfunction or setting of the expansion valves at the evaporator level. A high R744 load can also be the cause.

Please check these points in priority

**Symptoms that may indicate a malfunction of the closed blocked EEV and/or with an opening difficulty (reduced operating range)**

- There is a lack of cooling capacity observed.
- High Pressure cuts can be observed (E02)
- HP pressure (Pd) exceeds target value (Pd0). Therefore, the EEV control (Tr) indicates a high opening value and close to the maximum (between 400 and 480pls).  
By hand testing before and after the EEV, there must be a significant temperature difference between the upstream and downstream, if the EEV malfunctions.
- Moreover, the LP pressure (Ps) easily reaches its target value (Ps0), or it is below it. Thus the compressor (Ci) remains at a minimum speed of 30Hz (35Hz for a Sanden compressor)
- If the EEV malfunction is suspected, it is possible to swap the EEV coil with another coming from another loop in the unit
- The malfunction of the EEV can also be confirmed by taking it in the hand during the initialization phase described above. Shorter race times or a very low vibration sensation can confirm its bad condition

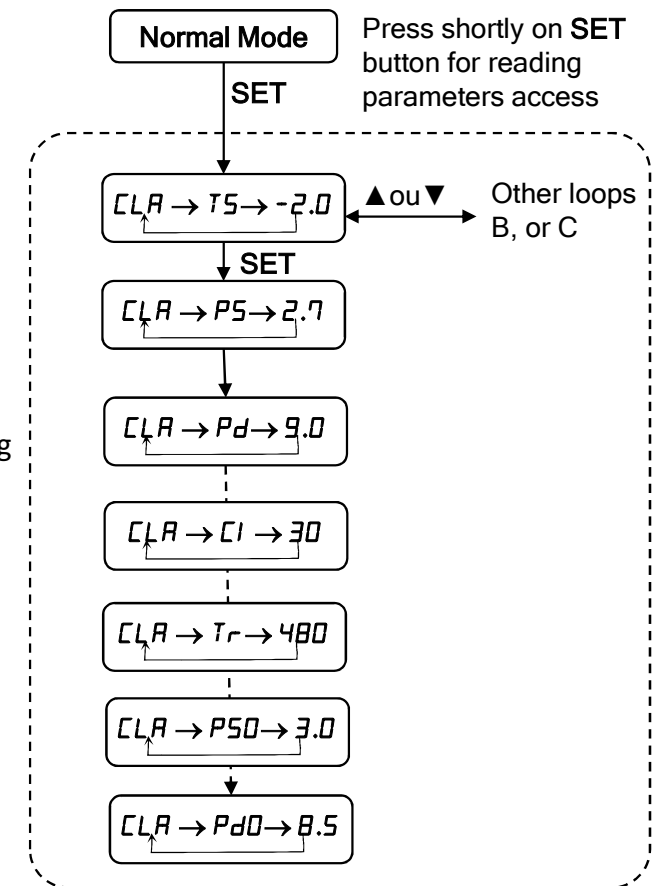

## 4. EEV coil checking

- CN12  
- EEV coil CHC
- CN13  
- EEV coil CLA
- CN14  
- EEV coil CLB



- Reference of the coil :  
92605-K2340 (ex 92605-62130)
- Description of the coil :  
EEV coil CKM M24SD

After disconnection from the PCB controller, or from the intermediate connector, measure the resistance value with an Ohmmeter between terminals of the coil.

**The normal resistance value is 185 Ohms +/-18 between terminals**

**185 ± 18 Ω**

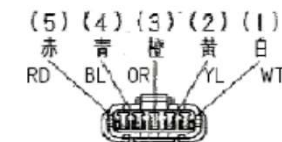



# 5. Replacement procedure

**CDU-L**

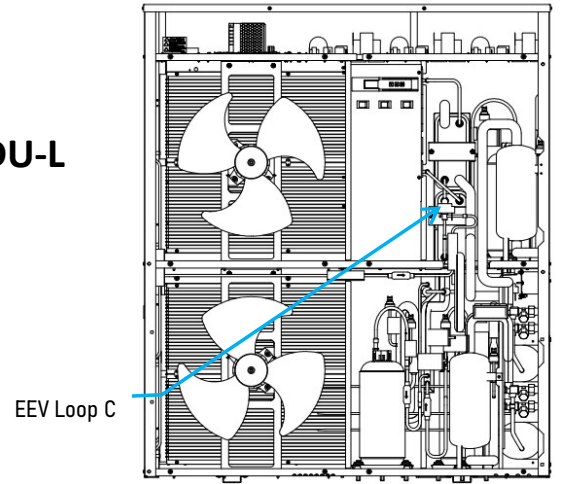

**CDU-M**

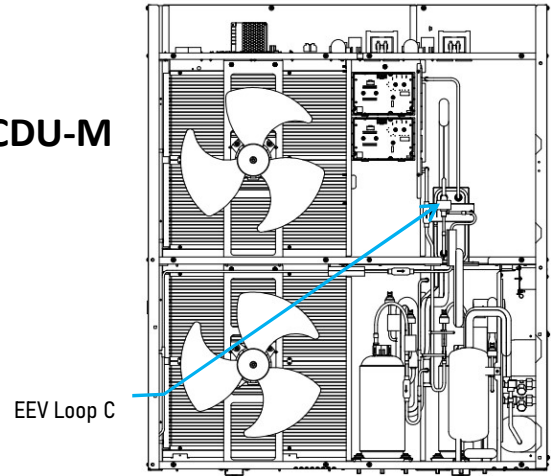

**EEV position**

EEV Loop B  
EEV Loop A

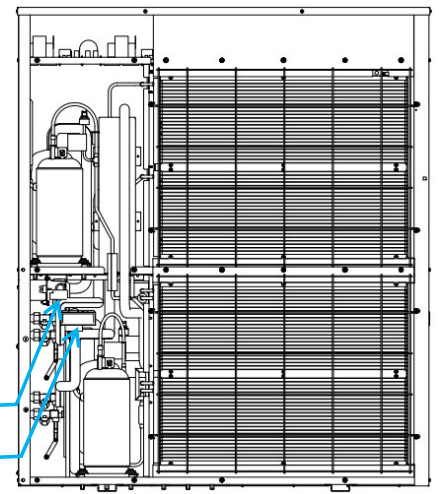

EEV Loop A

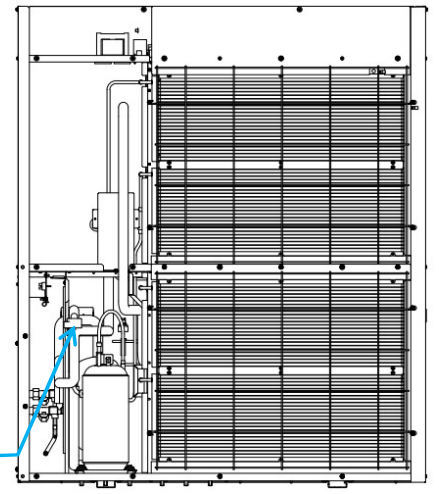

**CDU-S**

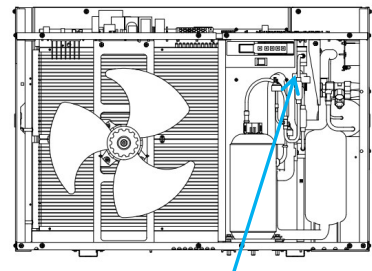

EEV Loop A

## 5. Replacement procedure

1. Remove refrigerant from service valve(s)
2. Check for no pressure LP/HP
3. Check for no voltage
4. Remove the necessary panels to access the EEV.
5. Remove the coil from the EEV.
6. Install the necessary protections inside the unit to disengage the EEV.
7. To replace the EEV, disconnect with a blowtorch the inlet and outlet tubes.
8. Install the new EEV, and properly protect the EEV body with a wet cloth.
9. Solder piping under nitrogen (be careful not to seal piping by adding too much filler metal)
10. Check circuit tightness with nitrogen and proceed vacuuming (see the guide : CDU piping work & start)
11. Reconnect the EEV coil, make sure the small pin is secured to the copper tube.
12. Power on the device again.
13. Check that there is no error code.
14. Charge the circuit with R744 refrigerant (start with 80% of the load)
15. Turn the compressor on using the button on the front.
16. Fill the R744 refrigerant load and refine if necessary.